

Surface Mount RF Power Attenuators

TFA-54D, TFA-84D, TFA-67D, TFA-37D are used for balanced coaxial attenuators, and are durable with large rated power.

In TFA-55DD, face down configuration on co-planer line show better return loss characteristics.

Long life and temperature stability of thin film technology realize better performance at a temperature range from -55C to + 155C.

Applications include gain control circuits, isolation circuits of power boost amplifiers at GHz, loss compensation of transmission line of data communication systems, detecting signal control of ATE-LSI test system-circuit board functional test systems, industrial measurement electronics, medical scientific electronics and miscellaneous communication systems.

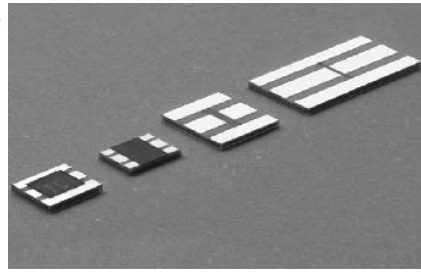

GENERAL SPECIFICATIONS

Model	Type	Impedance(*2)	Attenuation(*1)	Frequency Range	Power rating
TFA-54DD	Coaxial	50Ω	1, 2, 3, 4, 5, 6, 7, 8, 9, 10, 20, 30, 40dB	DC- 4GHz	0.25W
TFA-55DD	SMD	50Ω	1, 2, 3, 4, 5, 6, 7, 8, 9, 10, 20, 30, 40dB	DC- 4GHz	0.25W
TFA-85DD	Coaxial	50Ω	1, 2, 3, 4, 5, 6, 7, 8, 9, 10, 20, 30, 40dB	DC- 3GHz	0.50W
TFA-67DD	Coaxial	50Ω	1, 2, 3, 4, 5, 6, 7, 8, 9, 10, 20, 30, 40dB	DC- 3GHz	1.00W
TFA-37DD	Coaxial	50Ω	1, 2, 3, 4, 5, 6, 7, 8, 9, 10, 20, 30, 40dB	DC- 3GHz	1.00W
TFA-54DC	Coaxial	75Ω	1, 2, 3, 4, 5, 6, 7, 8, 9, 10, 20, 30, 40dB	DC- 4GHz	0.25W
TFA-55DC	SMD	75Ω	1, 2, 3, 4, 5, 6, 7, 8, 9, 10, 20, 30, 40dB	DC- 4GHz	0.25W
TFA-85DC	Coaxial	75Ω	1, 2, 3, 4, 5, 6, 7, 8, 9, 10, 20, 30, 40dB	DC- 3GHz	0.5W
TFA-67DC	Coaxial	75Ω	1, 2, 3, 4, 5, 6, 7, 8, 9, 10, 20, 30, 40dB	DC- 3GHz	1.00W
TFA-37DC	Coaxial	75Ω	1, 2, 3, 4, 5, 6, 7, 8, 9, 10, 20, 30, 40dB	DC- 3GHz	1.00W

Note:

(*1) Attenuation Tolerance at DC areas shown in following, 1dB is option, 2, 3, 4, 5, 6dB: +/-0.2dB, 7, 8, 9, 10dB: +/-0.3dB, 20, 30, 40dB: +/-0.4dB

(*2) 16dB attenuation is available optionally.

(*3) 7th character of P/N, "D" means "balanced" and "S" means "unbalanced"

(*4) 8th character of P/N, "D" means impedance of 50Ω, and "C" ditto of 75Ω

Face down installation, TFA-55DD

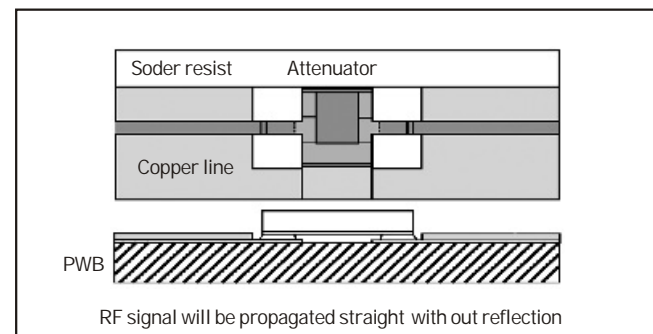

Materials

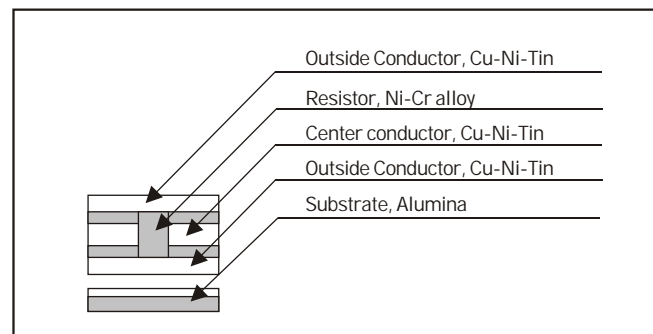

COAXIAL INSTALLATION, TFA-85D, TFA-67D

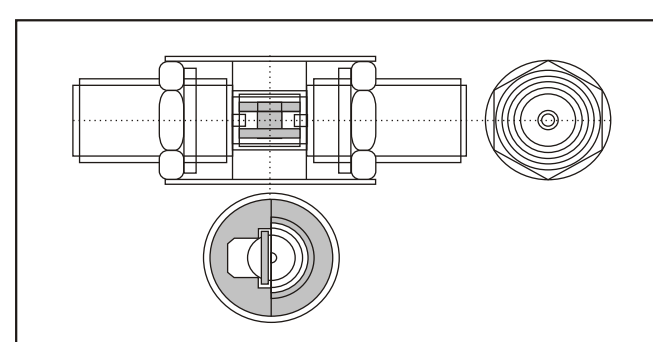

Power monitoring in circulator, TFA-68D

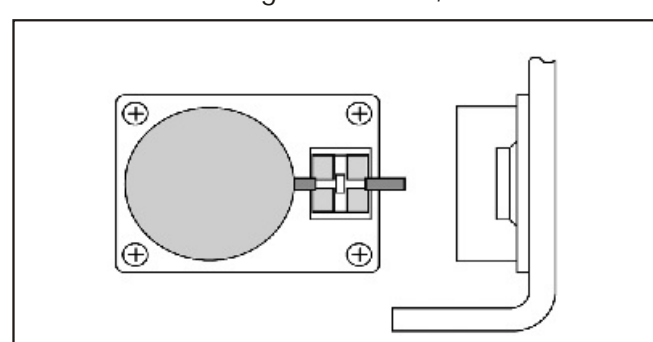

DIMENSIONS (mm)

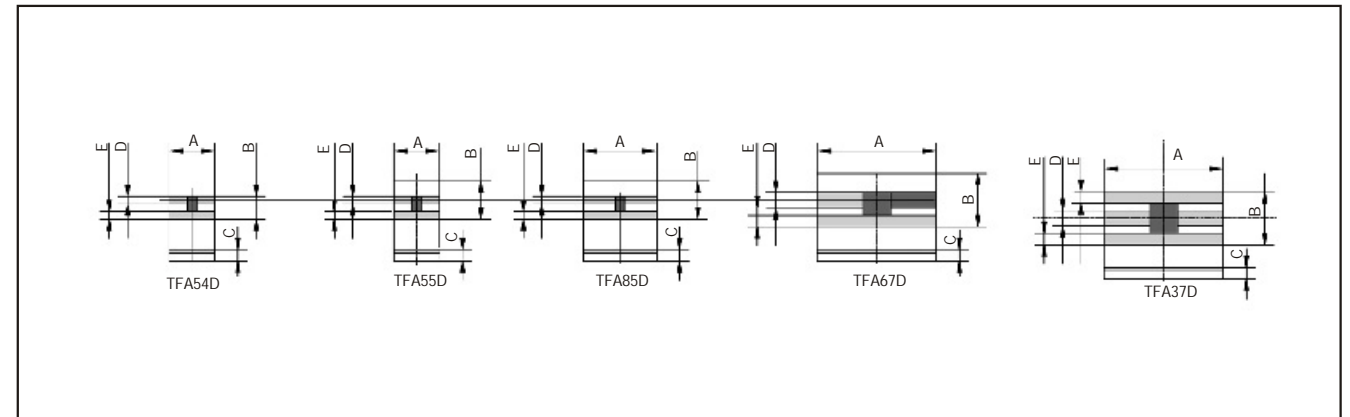

Model	Power	A	B	C	D	E
TFA-54D	1/4W	5.00	3.80	0.70	1.20	0.80
TFA-55D	1/4W	5.00	4.50	0.70	1.20	1.00
TFA-85D	1/2W	8.00	5.25	0.70	1.40	1.10
TFA-67D	1W	6.00	7.00	0.70	2.00	1.40
TFA-37D	1W	13.00	7.00	0.70	2.00	1.40

CHARACTERISTICS

Values in [] mean change in Ω after test

Operation Temp. Range		-55°C ~ +155°C
Storage Temperature		-55°C ~ +155°C
Characteristic Impedance		50Ω or 75Ω
Tolerance of Impedance	[±2%(G)]	Input DC volt in terminating out put with resistor when stable 1V DC volt source connected to input
Tolerance of Attenuation		Output DC volt in terminating output with resistor when stable 1V DC volt source connect to input. See Bottom of first page.
TCR of Impedance	[±50ppm/°C]	TC of input DC resistance in terminating output with resistor When stable 1V DC volt source connect to input.
TCR of Attenuation	[±50ppm/°C]	TC of output DC volt in terminating output with resistor When stable 1V DC volt source connect to input.
Rated Temperature	[±1%]	-55°C~70°C
Soldering Heat		350°C, 3seconds dipping.
Solderability	[95% converted]	
Moisture Resistance	[±1%]	Input DC resistance change under condition if 40°C temp and 90-95%RH, Power rating on-90min, off-30min, 1000h
Load Life	[±1%]	Input DC resistance change. Under condition of 70°C temp Power rating on-90min, off-30min, 1000h

Note: Above specifications are applied to TFA53S, TFA554D, TFA584S, TFA585D, TFA537S and TFA537D.

ORDERING PROCEDURE EXAMPLE

Ordering Example	Model	Characteristic Impedance	Attenuation	Additional	Power Rating
TFA54DD6dBZ00	TFA-54SD	50Ω	6dB	Z00	1/4W
TFA55DD10dBZ00	TFA-55DD	50Ω	10dB	Z00	1/4W
TFA85DD20dBZ00	TFA-85DD	50Ω	20dB	Z00	1/2W
TFA67DD30dBZ0	TFA-67DD	50Ω	30dB	Z00	1W
TFA37DD40dBZ00	TRF-37DD	55Ω	30dB	Z00	1W
TFA54DC6dBZ00	TFA-54SD	75Ω	6dB	Z00	1/4W
TFA55DC10dBZ00	TFA-55DD	75Ω	10dB	Z00	1/4W
TFA85DC20dBZ00	TFA-85DD	75Ω	20dB	Z00	1/2W
TFA67DC30dBZ0	TFA-67DD	75Ω	30dB	Z00	1W
TFA37DC40dBZ00	TRF-37DD	75Ω	30dB	Z00	1W

Note: Rating 30W of TFA68DD assume that the chip attached on proper heat sink by solder.

VHF/UHF Through-Hole Attenuators

These ARE RF attenuators with 50Ω, 75Ω, 300Ω and 600Ω characteristic impedances for through hole applications. SIP and DIP long life and temperature stability is achieved with Ni-Cr thin film and alumina substrates. The TFA series will be useful in isolation circuits, data transmission, mobile, RF application and measurements.

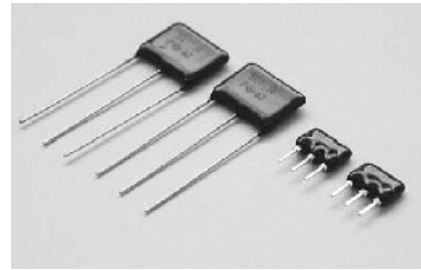

GENERAL SPECIFICATIONS

Model	Type	Impedance [Ω]	Attenuation	Frequency [Hz]	Power Rating
TFA-50TF	T-SIP 2.54pitch leads	50Ω	1, 2, 3, 4, 5, 6, 7, 8, 9, 10, 16, 20, 30dB	DC-100MHz	0.25W
TFA-75TF	T-SIP 2.54pitch leads	75Ω	1, 2, 3, 4, 5, 6, 7, 8, 9, 10, 16, 20, 30dB	DC-100MHz	0.25W
TFA-300TF	T-SIP 2.54pitch leads	300Ω	1, 2, 3, 4, 5, 6, 7, 8, 9, 10, 16, 20, 30dB	DC-100MHz	0.25W
TFA-600TF	T-SIP 2.54pitch leads	600Ω	1, 2, 3, 4, 5, 6, 7, 8, 9, 10, 16, 20, 30dB	DC-100MHz	0.25W
TFA-50T	T-SIP 5.0pitch leads	50Ω	1, 2, 3, 4, 5, 6, 7, 8, 9, 10, 16, 20, 30, 40dB	DC-100MHz	0.50W
TFA-75T	T-SIP 5.0pitch leads	75Ω	1, 2, 3, 4, 5, 6, 7, 8, 9, 10, 16, 20, 30, 40dB	DC-100MHz	0.50W
TFA-300T	T-SIP 5.0pitch leads	300Ω	1, 2, 3, 4, 5, 6, 7, 8, 9, 10, 16, 20, 30, 40dB	DC-100MHz	0.50W
TFA-600T	T-SIP 5.0pitch leads	600Ω	1, 2, 3, 4, 5, 6, 7, 8, 9, 10, 16, 20, 30, 40dB	DC-100MHz	0.50W
TFA-50TS	T-DIP leads	50Ω	1, 2, 3, 4, 5, 6, 7, 8, 9, 10, 16, 20, 30, 40dB	DC-100MHz	0.50W
TFA-300B	B-pai-DIP leads	75Ω	1, 2, 3, 4, 5, 6, 7, 8, 9, 10, 16, 20, 30, 40dB	DC-100MHz	0.50W
TFA-600B	B-pai-DIP leads	300Ω	1, 2, 3, 4, 5, 6, 7, 8, 9, 10, 16, 20, 30, 40dB	DC-100MHz	0.50W
TFA-85FD	T-SIP 2.54pitch leads	50Ω	1, 2, 3, 4, 5, 6, 7, 8, 9, 10, 16, 20, 30, 40dB	DC-200MHz	0.50W
TFA-85FC	T-SIP 2.54pitch leads	75Ω	1, 2, 3, 4, 5, 6, 7, 8, 9, 10, 16, 20, 30, 40dB	DC-200MHz	0.50W

CHARACTERISTICS

Values in [] mean change in Ω after test

Tolerance of Impedance	[±1%(F)]	Input DC resistance in terminating output port with precision resistor
Tolerance of Attenuation	[±1%]	Output DC volt in terminating output port with precision resistor When 1V stable DC source connected to input port.
TCR of Characteristic Impedance	[±50ppm/°C]	TC of input DC resistance in terminating output port with precision resistor
TCR of Attenuation	[±50ppm/°C]	Output DC volt TC in terminating output port with precision resistor When 1V stable DC source connected to input port
Soldering Heat	[±1%]	350°C, 3 seconds, dipping
Solderability	[75% Covered]	350°C, 3 seconds, dipping
Moisture Resistance	[±1%]	40°C, 95%RH, DC 0.1W, 1000 hours
Load Life	[±1%]	70°C, 90min on, 30min off, 100 hours

ORDERING PROCEDURE EXAMPLE

Ordering Example	Type and Impedance	Attenuation	Impedance Tolerance (%)	Note
TFA-50T6dB	TFA-50TF	-6dB	1(F)	
TFA-75T12dB	TFA-75TF	-12dB	1(F)	
TFA-600T20dB	TFA-600TF	-20dB	1(F)	

DIMENSIONS (mm)

TFA-50TF, TFA-75TF, TFA-300TF, TFA-600TF

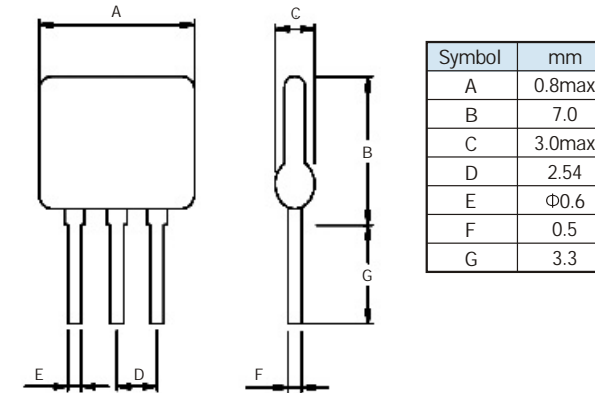

TFA-50T, TFA-75T, TFA-300T, TFA-600T

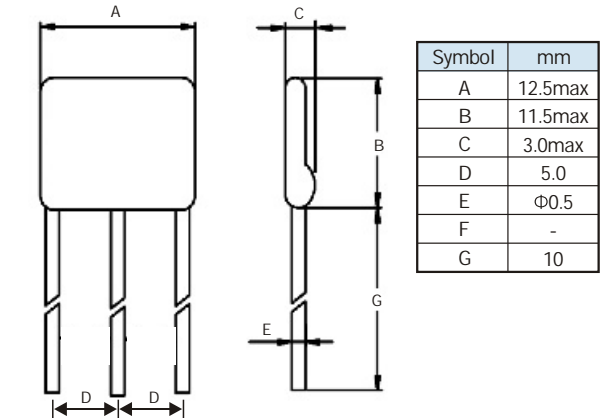

TFA-50B, TFA-75B, TFA-300B, TFA-600B

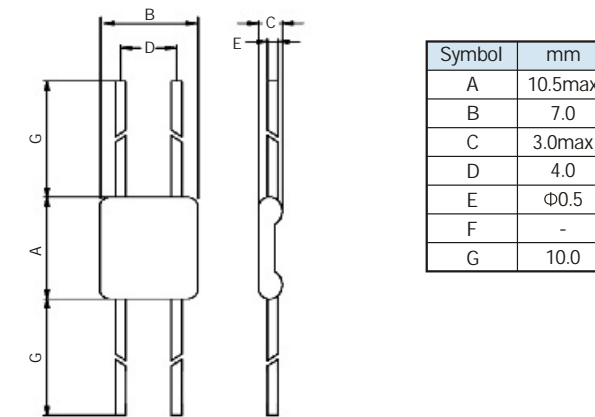

TFA-85FD, TFA-85FC

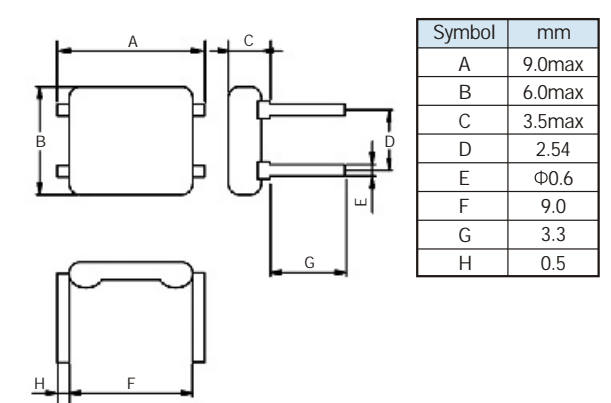

TFA-50TS, TFA-75TS, TFA-300TS, TFA-600TS

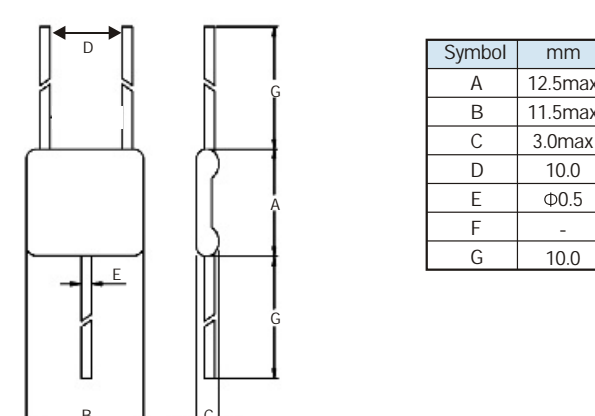

Equivalent Circuit of attenuator

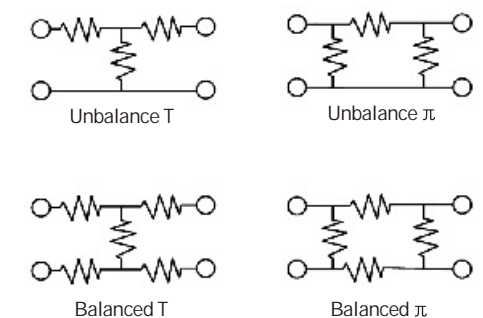

RF Power Resistors

Features and Applications

These components are designed for microwave applications and are available in wattages from 10-250W and ohmic values of 50-800ohms. Heat from the resistors can be extracted through back metal or flange to PCB or heat sink. The compact size and large power handling capability also have excellent RF characteristics. These units are RoHS compliant and are beryllium free. A 1% tolerance and 50ppm/C TCR ensure stable circuits. Applications include: RF Power amplifiers, RF power sources, fixed station for cell phones, RF measurement and terminations of circulators / isolators.

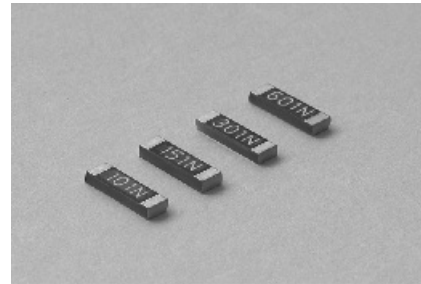

GENERAL SPECIFICATIONS

Model	Power Rating with Heatsink [W]	Resistance[Ω]	Tolerance(%)
TFH52, TFH72	10	50, 100, 150, 200, 250, 300, 400, 600, 800	F (±1.0)
TFK52, THK72	10		
TFR010-0	10		
TFR050-0	50		
TFR100-0	100		
TFR250-0	250		

CHARACTERISTICS

	TFH52, TFH72	TFK52, TFK72	TFR010-0	TFR050-0	TFR100-0	TFR250-0
Temp. Coefficient						±50ppm/°C
Rated Ambient Temp.						70°C
Operating, Temp Range						-55°C to +155°C
Load Life						±0.5%
Humidity						±0.5%
Series Inductance	3.2μH	3.2μH				-
Parallel Capacitance	<0.05pF	<0.05pF				-

DERATING CURVE & APPLICATIONS

An application of TFH72

Heat-extraction system

DIMENSIONS (mm)

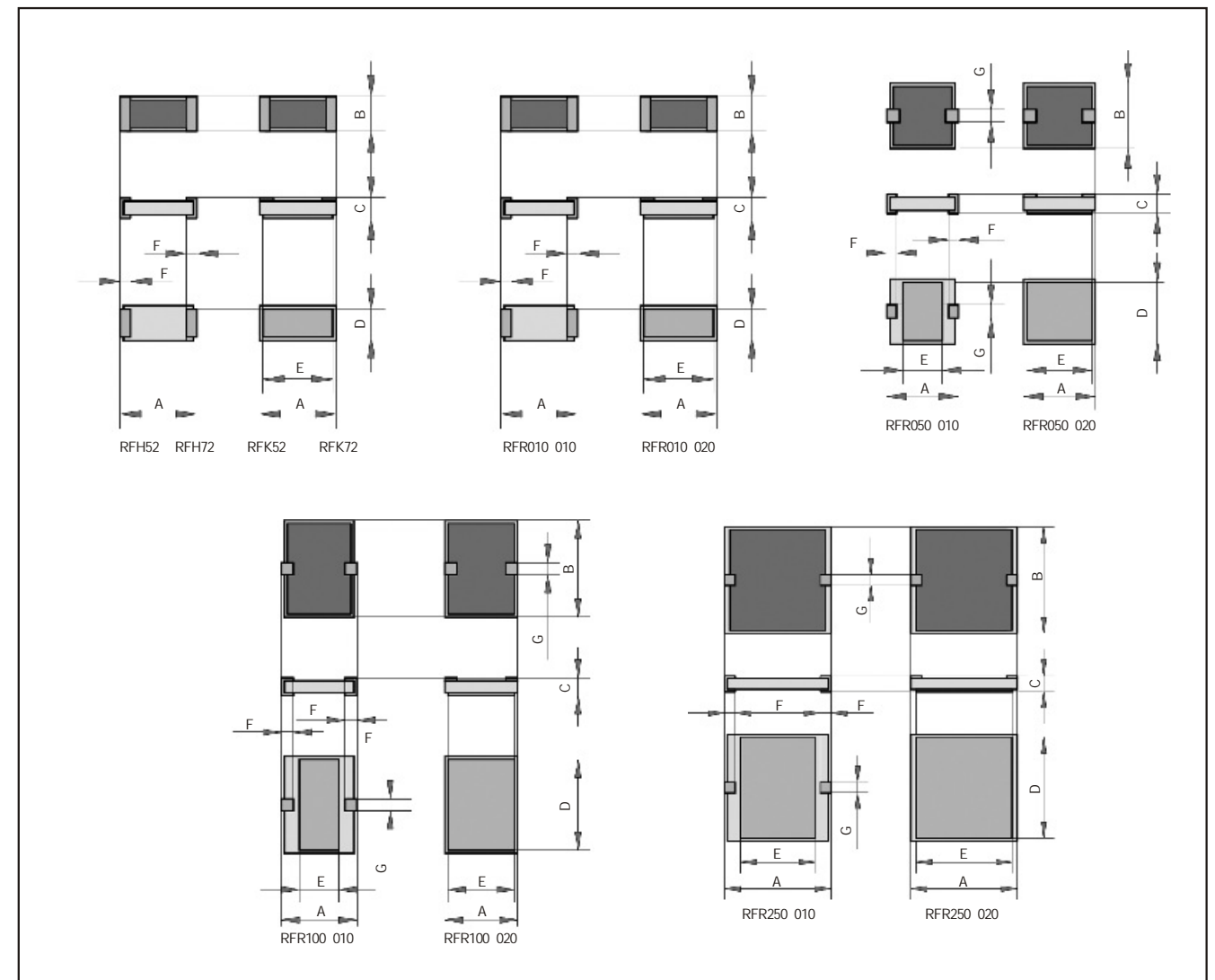

Model	Power	A	B	C	D	E	F	G
TFH52	10W	5.0	2.5	1.2max	-	-	0.8	-
TFH72	10W	7.0	2.0	1.2max	-	-	0.8	-
TFK52	10W	5.0	2.5	1.2max	2.3	4.8	0.8	-
TFK72	10W	7.0	2.0	1.2max	1.8	6.8	0.8	-
TFR010 010	10W	5.08	2.54	1.05	-	-	1.27	-
TFR020 020	10W	5.08	2.54	1.05	2.34	4.88	1.27	-
TFR050 010	50W	5.08	5.08	1.05	4.84	2.00	1.27	1.27
TFR050 020	50W	5.08	5.08	1.05	4.84	4.68	1.27	1.27
TFR100 010	100W	5.84	8.89	1.05	8.49	2.54	1.27	1.27
TFR100 020	100W	5.84	8.89	1.05	8.49	5.45	1.27	1.27
TFR250 010	250W	9.52	9.52	1.05	9.12	6.00	1.27	1.27
TFR250 020	250W	9.52	9.52	1.05	9.12	9.12	1.27	1.27

MATERIALS

Part	Material
(1) Cold end Terminal	Tin plated Ni-Cu
(2) Element	Ni-Cr
(3) Substrate	ALN
(4) Hot end Terminal	Tin plated Ni-Cu
(5) Back Metal	Tin plated Ni-Cu

FOOT PATTERN



(mm)	H	J	K	L	M	N
TFH52	5.40	2.70	1.20	-	-	-
TFH72	7.40	2.40	1.20	-	-	-
TFK52	5.40	2.70	-	-	-	-
TFK72	7.40	2.40	-	-	-	-
TFR010 010	5.48	2.94	1.67	-	-	-
TFR010 020	5.48	2.94	-	-	-	-
TFR050 010	5.48	5.48	1.47	1.47	2.54	2.14
TFR050 020	5.48	5.48	-	-	-	-
TFR100 010	6.24	9.29	1.47	1.47	3.30	2.90
TFR100 020	6.24	9.29	-	-	-	-
TFR250 010	9.92	9.29	1.47	1.47	6.98	6.58
TFR250 020	9.92	9.29	-	-	-	-

ORDERING PROCEDURE EXAMPLE

Ordering Example	Model	Outlook	TCR	Resistance	Tolerance	Bulk/Tape	Remarks
TFH52 C200 OhmFZ00	TFH52		C	200Ω	F	Z00-Z01	Bulk-Tape
TFH72 C200 OhmFZ00	TFH72		C	200Ω	F	Z00	Bulk-Tape
TFK52 C200 OhmFZ00	TFK52		C	200Ω	F	Z00	Bulk-Tape
TFK72 C200 OhmFZ00	TFK72	010	C	200Ω	F	Z00	Bulk-Tape
TFR010 010 C50 OhmFZ00	TFR010	020	C	50Ω	F	Z00	Bulk-Tape
TFR010 020 C50 OhmFZ00	TFR010	010	C	50Ω	F	Z00	Bulk-Tape
TFR050 010 C50 OhmFZ00	TFR050	020	C	50Ω	F	Z00	Bulk-Tape
TFR050 020 C50 OhmFZ00	TFR050	010	C	50Ω	F	Z00	Bulk-Tape
TFR100 010 C50 OhmFZ00	TFR100	020	C	50Ω	F	Z00	Bulk-Tape
TFR100 020 C50 OhmFZ00	TFR100	010	C	50Ω	F	Z00	Bulk-Tape
TFR250 010 C50 OhmFZ00	TFR250	020	C	50Ω	F	Z00	Bulk-Tape
TFR250 020 C50 OhmFZ00	TFR250		C	50Ω	F	Z00	Bulk-Tape

TEMPERATURE RISE & DERATING CURVE

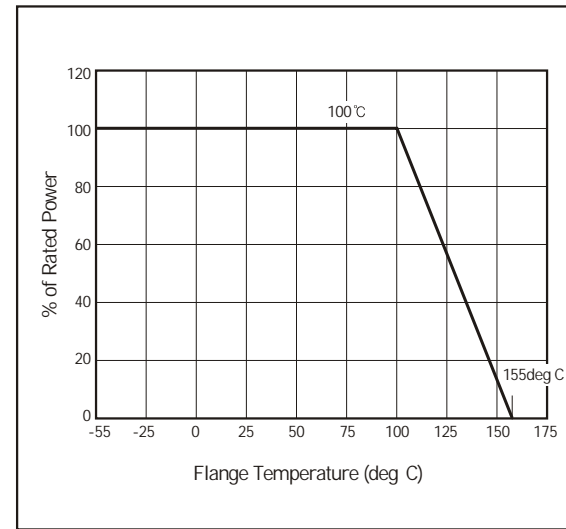
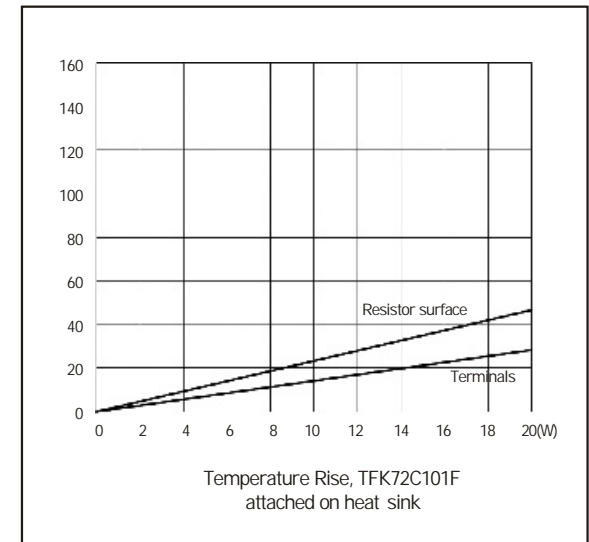
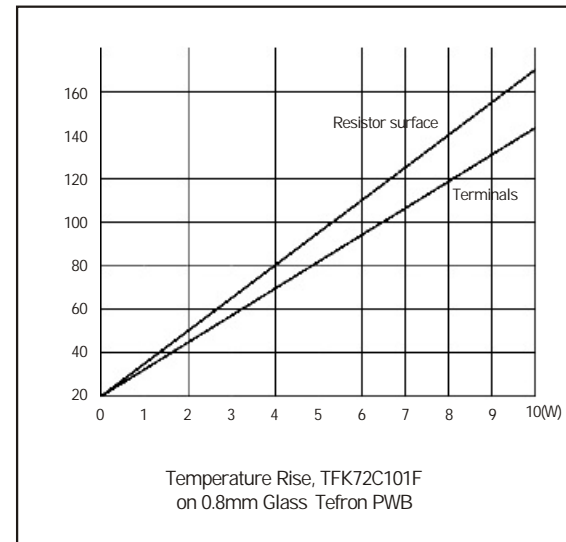

FREQUENCY CHARACTERISTICS

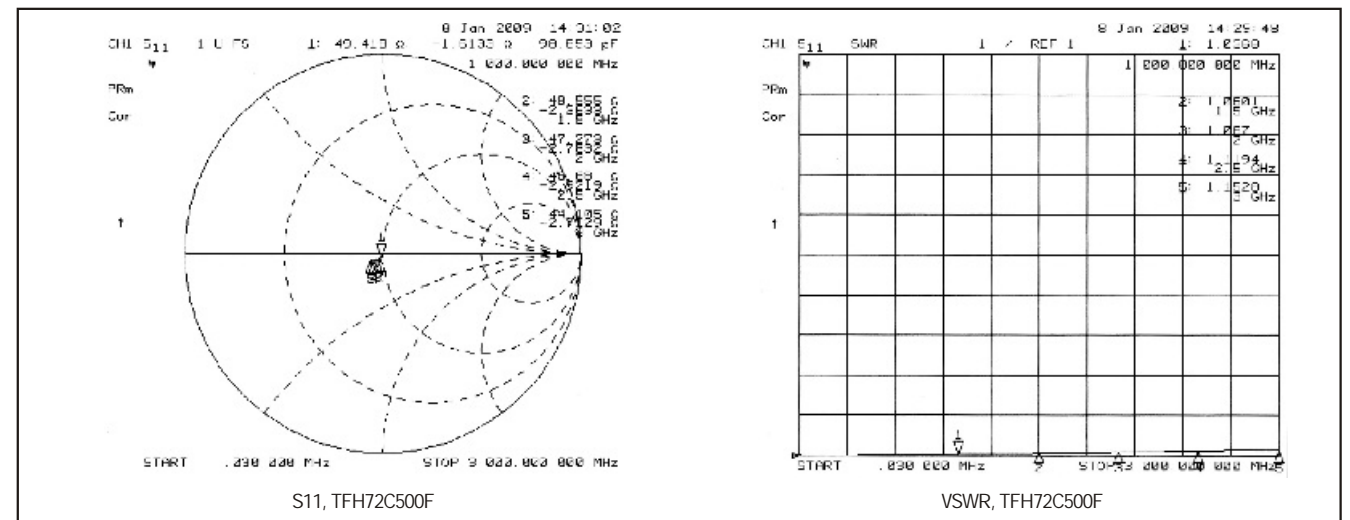

Surface Mount High Power Terminations

High power surface mount terminations for all DC to 5GHz applications. The small size and wide frequency range specifications are made possible with a large heat conducting AlN substrate. Mechanical strength metallization is possible using a sputtered thin film technology. 50 ohm resistance with tolerances of 1% and wattages of 10W, 50W, 100W and 250W are provided as standard. Other resistances and powers are available. Long life and temperature stability are the result of Ni-Cr thin film technology. Flanged terminations are available with the TFTF series. Applications include: Terminations for isolator / circulator, fixed station of mobile communication electronics, high power microwave amplifiers.

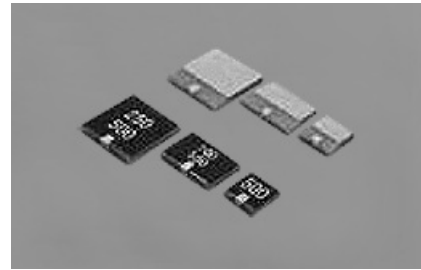

GENERAL SPECIFICATIONS

Model	Power Rating	*Maximum Power	Resistance Range	Tolerance(%)	TCR(ppm/°C)
TFT010	10W	20W	50 Ω	F (±1)	50
TFT050	30W	50W			
TFT100	100W	200W			
TFT250	250W	500W			

Maximum Power: The condition is pulse < 1 second.

CHARACTERISTICS

Model	TFT010	TFT050	TFT100	TFT250	Conditions
Heat Resistance[C/W]	6.5	2.5	1.3	0.5	
VSWR at 3GHz	1.15	1.15	1.20	1.20	
Max Operating Temperature	-55 °C ~ 155 °C				
Storage Temperature	-55 °C ~ 155 °C				

SURFACE TEMP. INCREASE VERSUS POWER LOADS / DERATING CURVES

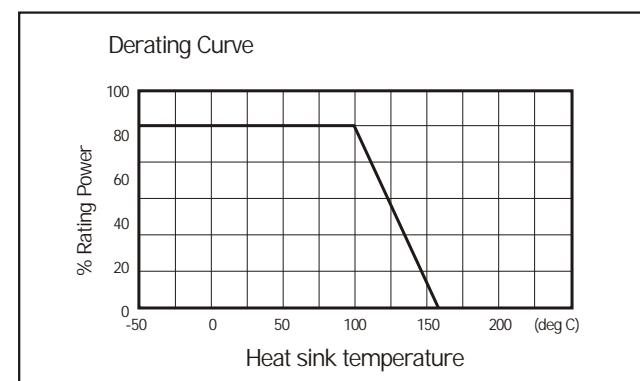
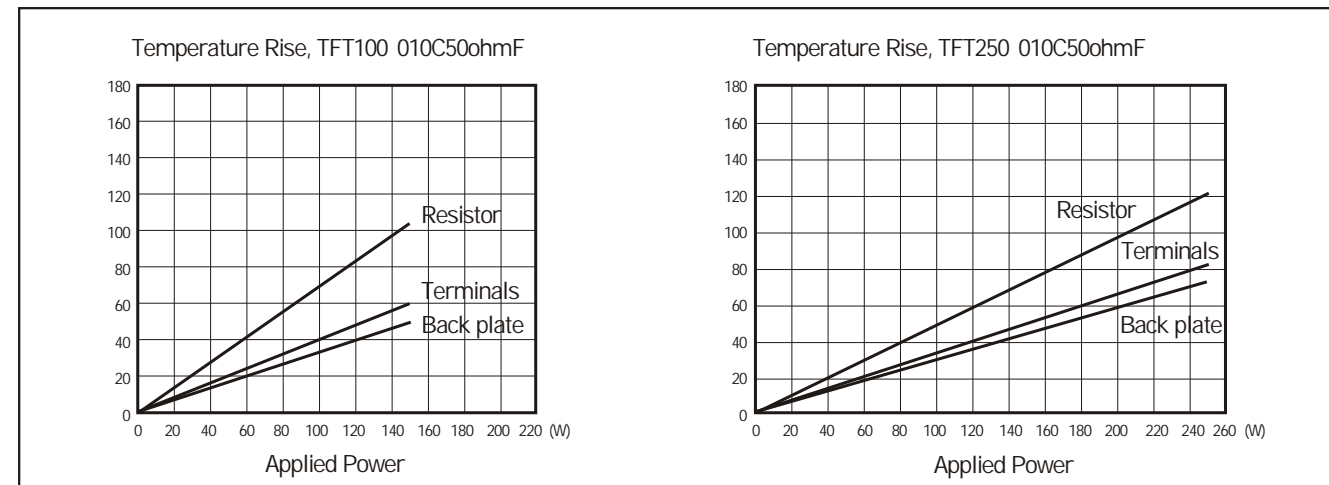

Note.
 (1) Other resistance value and substrate thickness are available. Please consult RARA factory.
 (2) Power rating assumes that chip attached on metal plate.
 (3) Solder joint design should assure a solder thickness within 50 micron meters.

DIMENSIONS(mm)

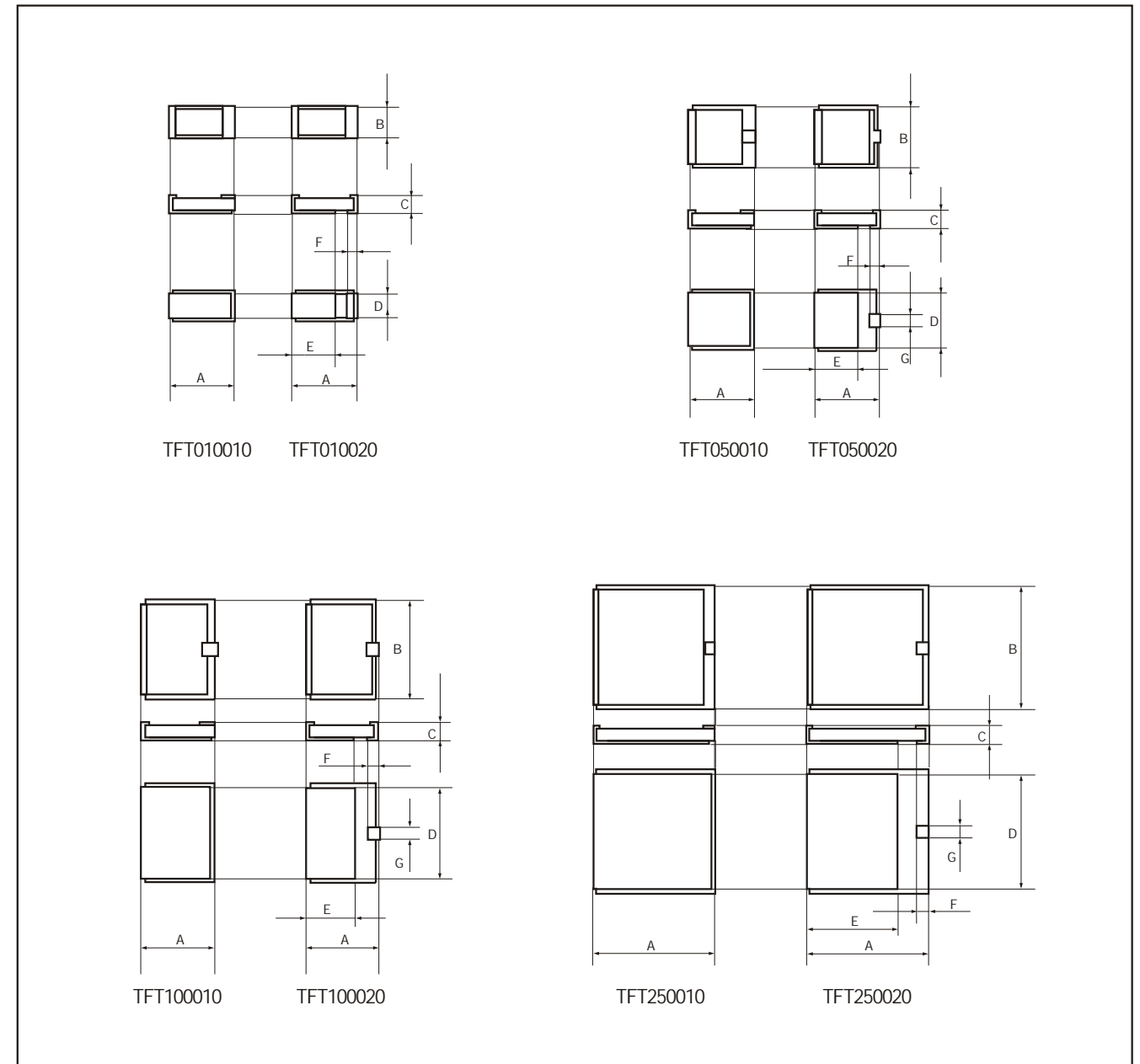

Type	Power	A	B	C	D	E	F	G
TFT010 010	10W	5.08	2.54	1.05	2.34	-	1.27	1.27
TFT010 020		5.08	2.54	1.05	2.30	2.54	1.27	1.27
TFT050 010	50W	5.08	5.08	1.05	4.84	-	1.27	1.27
TFT050 020		5.08	5.08	1.05	4.84	2.54	1.27	1.27
TFT100 010	100W	5.84	8.89	1.05	8.49	-	1.27	1.27
TFT100 020		5.84	8.89	1.05	8.49	6.35	1.27	1.27
TFT250 010	250W	9.52	9.52	1.05	9.12	-	1.27	1.27
TFT250 020		9.52	9.52	1.05	9.12	6.98	1.27	1.27

FOOT PATTERN DESIGN

	H	J	K	L
TFT010 010	5.48	2.94	-	-
TFT010 020	5.48	2.94	(2.98)	1.0
TFT050 010	5.48	5.48	-	-
TFT050 020	5.48	5.48	(2.98)	1.0
TFT100 010	6.24	9.29	-	-
TFT100 020	6.24	9.29	(3.24)	1.5
TFT250 010	9.92	9.29	-	-
TFT250 020	9.92	9.29	(6.92)	1.5

MATERIALS

	Substance	Material
(1)	Cold end Terminal	Tin plated Ni-Cu
(2)	Resistive	Ni-Cr
(3)	Substrate	ALN
(4)	Hot end Terminal	Tin plated Ni-Cu

ORDERING PROCEDURE EXAMPLE

Ordering P/N	Type	Outlook	TC	Resistance	Tolerance	Bulk/Tape	Remarks
TFT010 010C50 ΩFZ00	TFT010	010	C	50 Ω	F	Z00-Z01	Bulk-Tape
TFT010 020C50 ΩFZ00	TFT010	020	C	50 Ω	F	Z00-Z01	Bulk-Tape
TFT050 010C50 ΩFZ00	TFT050	010	C	50 Ω	F	Z00-Z01	Bulk-Tape
TFT050 010C50 ΩFZ00	TFT050	020	C	50 Ω	F	Z00-Z01	Bulk-Tape
TFT100 010C50 ΩFZ00	TFT100	010	C	50 Ω	F	Z00-Z01	Bulk-Tape
TFT100 020C50 ΩFZ00	TFT100	020	C	50 Ω	F	Z00-Z01	Bulk-Tape
TFT250 010C50 ΩFZ00	TFT250	010	C	50 Ω	F	Z00-Z01	Bulk-Tape
TFT250 020C50 ΩFZ00	TFT250	020	C	50 Ω	F	Z00-Z01	Bulk-Tape

RF Disk Resistor

Features and Applications

These are disk resistors designed for high frequency terminations. They are easy to integrate with coaxial connectors to printed circuit boards. This will result in a high performance termination. These have thin film elements mounted on a highly conductive substrate. These have a maximum operation temperature of 155C. These have a low TCR of +/-25ppm/K and +/-1% tolerance. Original spoke-trimming ensures excellent stability and long life. Application include: Mobile communications system, measuring instruments, high frequency power supply equipment.

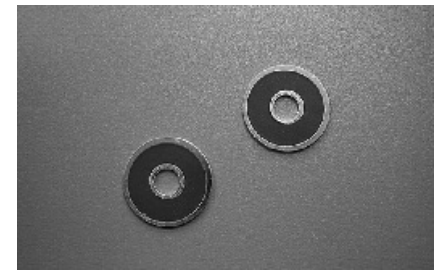

GENERAL SPECIFICATIONS

Model	Rated Power[W]	Resistance[Ω]	Absolute T.C.R	Tolerance(%)
TFE030	0.5W	50	±100ppm/°C	F (1.0) J(±5)
TFE048	1.0W			
TFE078	1.0W			
TFE099	2W			
TFE205	5W			

CHARACTERISTICS

Temperature Cycle	±0.5%	-55°C 30min., +120°C 30min., 20cycles.
Max Working Voltage		$E = \sqrt{P \cdot R}$
Short Time Over Load	±0.5%	Rating Power *2.5, 5seconds
Solderability	Covered 95%	235°C, 2seconds
Solvent	No damage	IPA test
Terminal Strength	±0.5%	
Withstanding Voltage	±0.3%	
Soldering Heat	±0.3%	350°C, 3seconds
Load Life	±0.5%	1000hours
Humidity	±0.5%	1000hours
Shelf Life Stability	±0.3%	One year at 25°C
Operating Temp		-55°C to +155°C
Storage Temp. Range		-55°C to +155°C

DIMENSIONS [mm]

Model	A max(mm)	B min(mm)	C	D	E
TFE030	3.0 +0.0/-0.2	1.4 +0.2/-0.0	0.8 ± 0.1	0.2 ± 0.05	0.2 ± 0.05
TFE048	4.8 +0.0/-0.2	1.4 +0.2/-0.0	0.8 ± 0.1	0.2 ± 0.05	0.2 ± 0.05
TFE078	7.8 +0.0/-0.2	2.9 +0.2/-0.0	0.8 ± 0.1	0.2 ± 0.05	0.2 ± 0.05
TFE099	9.9 +0.0/-0.2	2.9 +0.2/-0.0	0.8 ± 0.1	0.2 ± 0.05	0.2 ± 0.05
TFE205	20.5 +0.0/-0.2	6.0 +0.2/-0.0	0.8 ± 0.1	0.2 ± 0.05	0.2 ± 0.05

DERATING CURVES

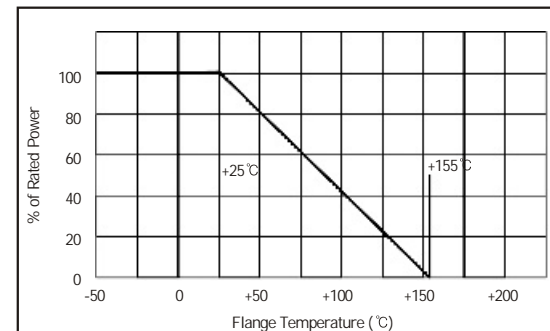

ORDERING PROCEDURE EXAMPLE

Ordering Example	Model	TCR	Resistance	Tolerance(%)	Code
TFE030E50RFZ00	TFE030	A(±100ppm/°C)	50Ω	F(±1)	Z00
TFE048E50RFZ00	TFE048		50Ω	F(±1)	Z00
TFE078E50RFZ00	TFE078		50Ω	F(±1)	Z00

RF Flanged Power Resistors

Features and Applications

These components are designed for microwave applications and are available in wattages from 10W to 250W and ohmic values of 50-800ohms. Heat from the resistors can be extracted through back metal or flange to PCB or heat sink. The compact size and large power handling capability also have excellent RF characteristics. These units are RoHS compliant and are beryllium free. A 1% tolerance and 50ppm/C TCR ensure stable circuits. Applications include: RF power amplifiers, LNA RF power sources, fixed station for cell phones, RF measurement and terminations of circulators/isolators.

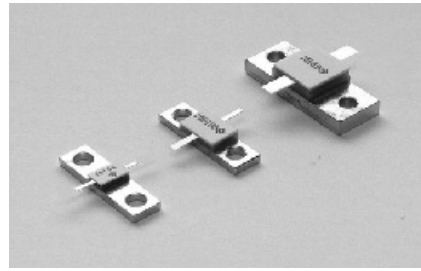

GENERAL SPECIFICATIONS

Model	Power Rating [W]	Resistance[Ω]	Tolerance(%)
TFR010	10	50, 100, 150, 200, 250, 300 400, 600, 800	F (1.0)
TFR050	50		
TFR100	100		
TFR250	250		

CHARACTERISTICS

Model	TFR010	TFR050	TFR100	TFR250
Operating Temperature Range				-55°C to +155°C
Temp. Coefficient				±50ppm/°C
Storage Temperature Range				-55°C to +155°C
Load Life				±0.5
Humidity				±0.5
Series Inductance				-
Parallel Capacitance				-

DERATING CURVE & APPLICATIONS

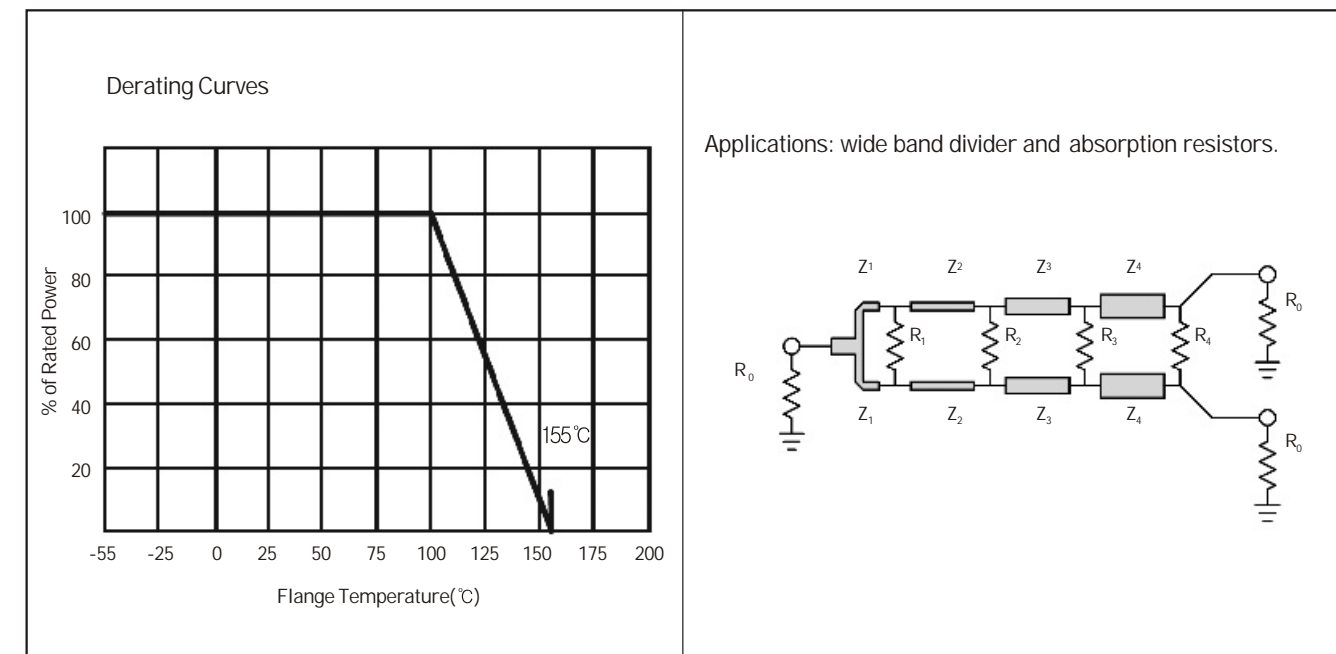

DIMENSIONS [mm]

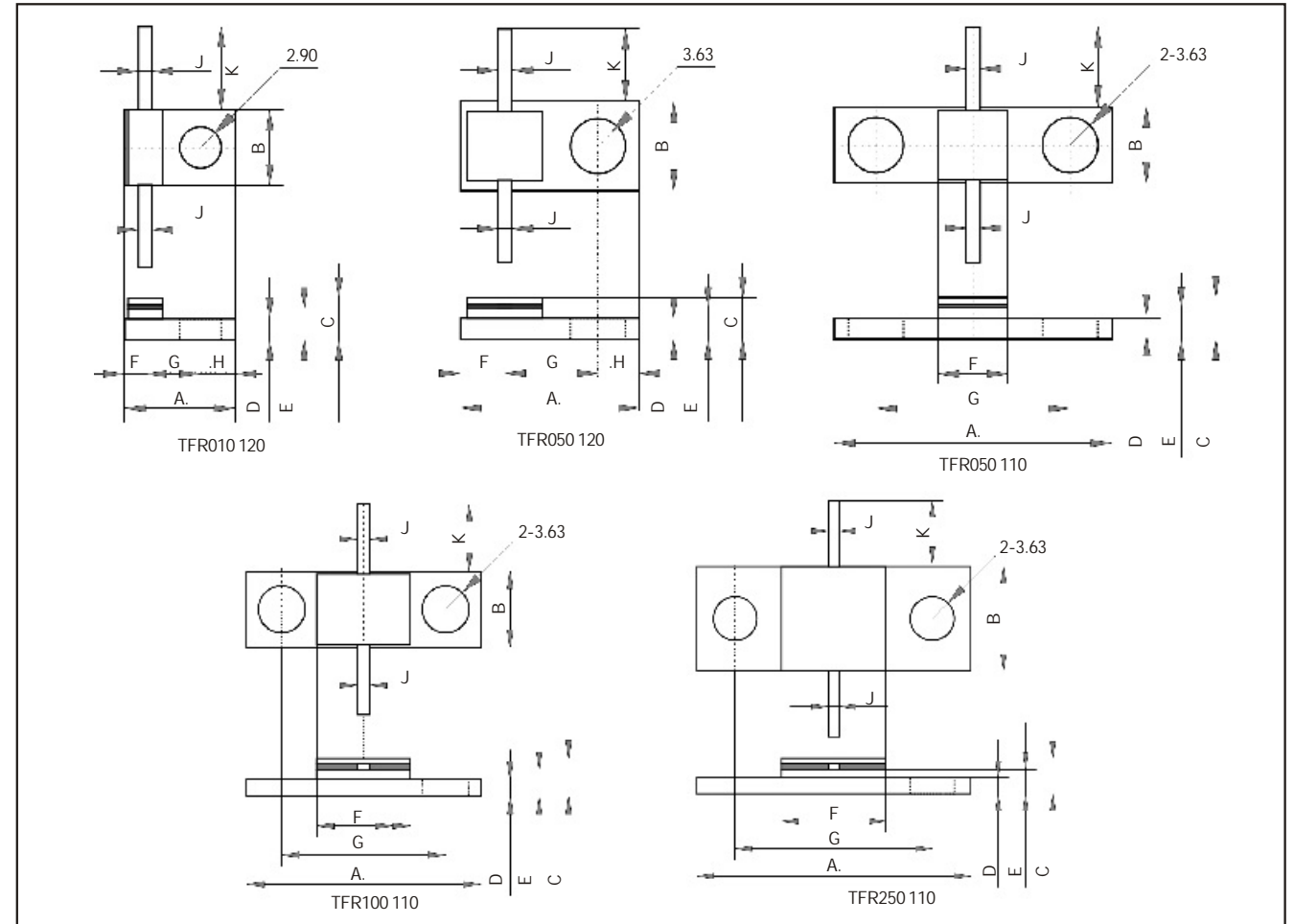

	A	B	C	D	E	F	G	H	J	K
TFR010	7.10	5.10	3.10	1.50	2.20	1.50	3.50	2.10	0.80	5.08
TFR050	13.08	6.35	3.10	1.50	2.20	(2.54)	7.49	3.05	0.80	5.08
TFR050	20.30	5.70	3.10	1.50	2.60	5.08	14.20	-	1.50	5.08
TFR100	20.30	6.35	3.10	1.50	2.60	8.89	14.20	-	1.50	5.08
TFR250	25.00	9.53	4.50	3.00	4.10	9.52	18.42	-	3.00	5.08

MATERIALS

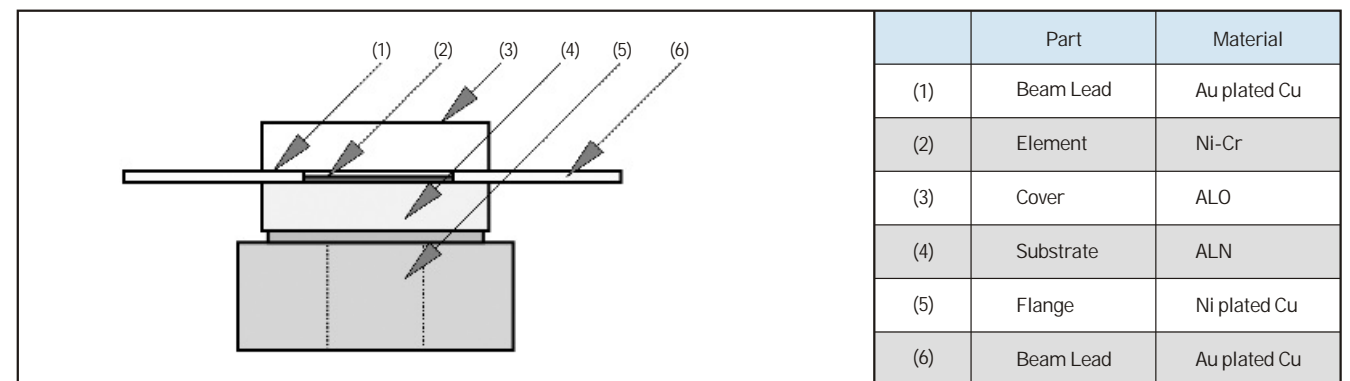

ORDERING PROCEDURE EXAMPLE

Ordering Example	Model	Outlook	TCR	Resistance	Tolerance	Bulk/Tape	Package
TFR010 120C100ohmFZ00	TFR010	120	C	100Ω	F	Z00	Tray
TFR050 120C150ohmFZ00	TFR050	120	C	150Ω	F	Z00	Tray
TFR050 110C200ohmFZ00	TFR050	110	C	200Ω	F	Z00	Tray
TFR100 110C300ohmFZ00	TFR100	110	C	400Ω	F	Z00	Tray
TFR250 110C800ohmFZ00	TFR250	110	C	800Ω	F	Z00	Tray

Power Flange Terminations

Features and Applications

These are high power, flanged terminations for all DC circuits up to 5GHz. The small size and wide frequency range are attained with a large heat conducting ALN substrate. Sufficient mechanical strength is attained from spattered thin metallization.

These are standard with a 50ohm resistance, a tolerance of 1% and 10W, 50W, 100W and 250W. Ni-Cr thin film technology ensures long life. Applications include: Terminations for isolator/circulators, fixed station of mobile communication electronics, and high power microwave amplifiers.

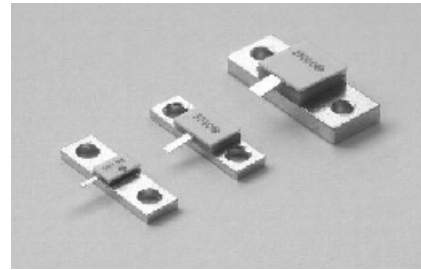

GENERAL SPECIFICATIONS

Model	Power Rating[W]	1) Maximum Power[W]	Resistance[Ω]	Tolerance(%)
TFT010	10	20	50	1.0
TFT050	30	50		
TFT100	100	200		
TFT250	250	500		

1) Test conditions: Pulse < 1second

CHARACTERISTICS

Model	TFT010	TFT050	TFT100	TFT250
Max Operating Temperature				-55°C to +155°C
Temp. Coefficient				±50ppm/°C
Heat Resistance	6.5°C/W	2.5°C/W	1.3°C/W	0.5°C/W
VSWR at 1GHz	1.15	1.15	1.20	1.20
Storage Temperature				-55°C to +155°C

MATERIALS

Part	Material
(1) Cold end Terminal	Tin plated Ni-Cu
(2) Element	Ni-Cr
(3) Cover	ALO
(4) Substrate	ALN
(5) Flange	Ni plated Cu
(6) Beam Lead	Au plated Cu

ORDERING PROCEDURE EXAMPLE

Ordering Example	Model	Outlook	TCR	Resistance	Tolerance	Bulk/Tape	Remarks
TFT010 120C50ohmFZ00	TFT010	120	C	50Ω	F	Z00	Tray
TFT050 110C50ohmFZ00	TFT050	110	C	50Ω	F	Z00	Tray
TFT050 120C50ohmFZ00	TFT050	120	C	50Ω	F	Z00	Tray
TFT050 130C50ohmFZ00	TFT050	130	C	50Ω	F	Z00	Tray
TFT050 140C50ohmFZ00	TFT050	140	C	50Ω	F	Z00	Tray
TFT100 110C50ohmFZ00	TFT100	110	C	50Ω	F	Z00	Tray
TFT250 110C50ohmFZ00	TFT250	110	C	50Ω	F	Z00	Tray

DIMENSIONS (mm)

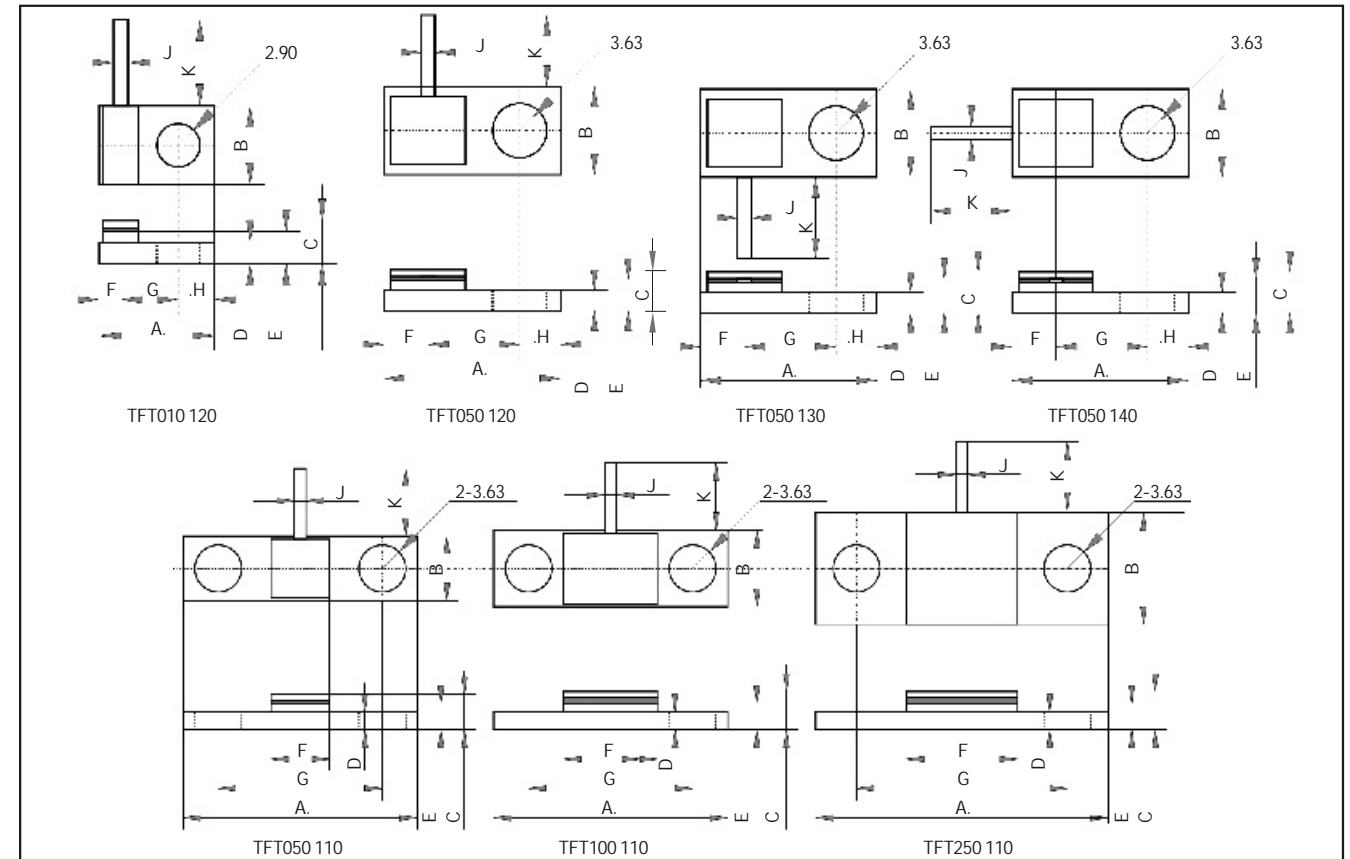

	A±0.1	B±0.1	C±0.1	D±0.1	E±0.1	F±0.1	G±0.1	H±0.1	J±0.1	K±0.1
TFT010	7.10	5.10	3.10	1.50	2.20	1.50	3.50	2.10	0.80	5.08
TFT050	13.08	6.35	3.10	1.50	2.20	(2.54)	7.49	3.05	0.80	5.08
TFT050	20.30	5.70	3.10	1.50	2.60	5.08	14.20	-	1.50	5.08
TFT100	20.30	6.35	3.10	1.50	2.60	8.89	14.20	-	1.50	5.08
TFT250	25.00	9.53	4.50	3.00	4.10	9.52	18.42	-	3.00	5.08